



**FT FLUIDOTEHNIC**

# **ELECTROHYDRAULIC THRUSTERS**

---

CATALOG OF DEVICES

**FT** [www.fluidotehnic.com](http://www.fluidotehnic.com)



**Fluidotehnic d.o.o.**  
**Serbia**

36210 Vrnjacka Banja  
Rudjinci 175/A

**Tel:** +381-(0)36-631-710  
+381-(0)36-631-711

**Fax:** +381-(0)36-631-712

**[www.fluidotehnic.com](http://www.fluidotehnic.com)**  
[office@fluidotehnic.com](mailto:office@fluidotehnic.com)



# SERIES "ESM"

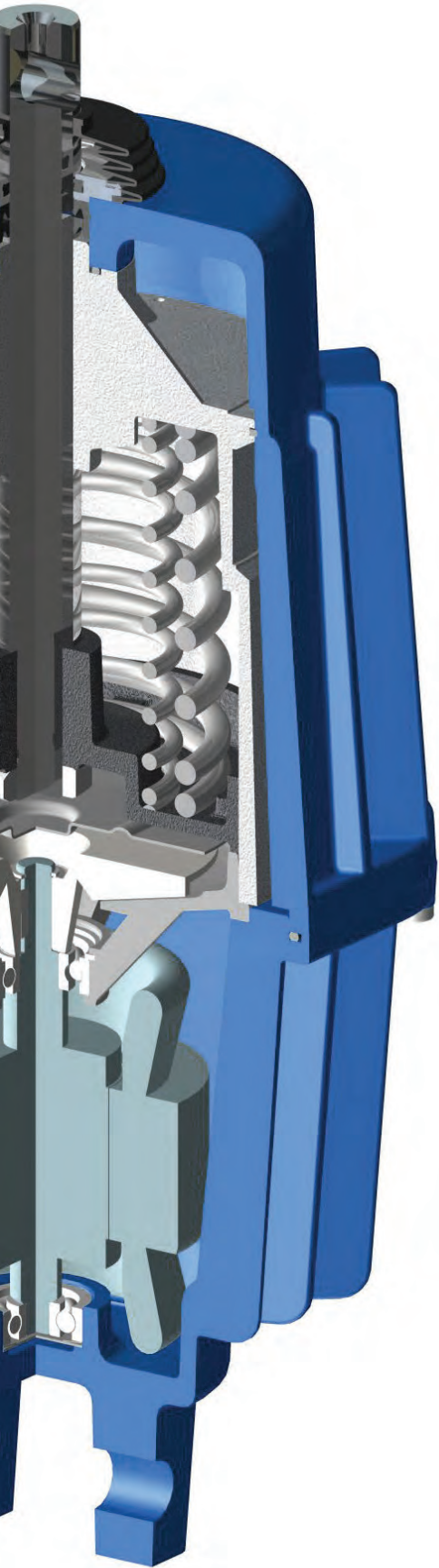

Easy installation and deinstallation

Short actuating times

High operational safety

Ability to work from  $-45^{\circ}\text{C}$  to  $+70^{\circ}\text{C}$

Standard version 2000c/h or ED100% (S1)



Different voltages and frequencies  
of electric power



Standard mechanical protection IP66



Resistance to heavy duty



External controllers of device



Internal controllers of device



## TECHNICAL DESCRIPTION OF THE DEVICE

Housing of the motor **(1)** is constructed with eyelet connection and can be fixed on fundament by a bolt. There is also oil drain plug on the housing. Driving motor stator **(3)** (squirrel cage asynchronous motor) is fitted in the housing. Connecting box for electrical supply **(11)** is fixed on the housing hermetically separated from the inside of the housing. The rotor **(2)** is fixed in the housing by its downside, and upside fitted in the turbine bearing **(4)**. The turbine wheel **(5)** is mounted on the rotor shaft. The guide cylinder **(8)** with piston **(12)** and rod **(14)** is located upper the turbine.

In the guide cylinder is also screw **(13)** for adjusting speed of the rod. On the upper side the guide cylinder is covered by upper housing **(10)**, which with the motor housing forms a functional entirety.

The transformer oil fills interior of the device. The electric motor drives the turbine, which produce oil pressure downside of the piston. The piston and the rod are forced to move upward. The oil from upside of the piston returns through the holes to the turbine inlet. Hydraulic force is completely independent of the piston position, it depends only of the speed of turbine (current frequency), turbine size, and of the piston diameter. When lifting, motion is uniformly in the range of nominal force, independent of the load.

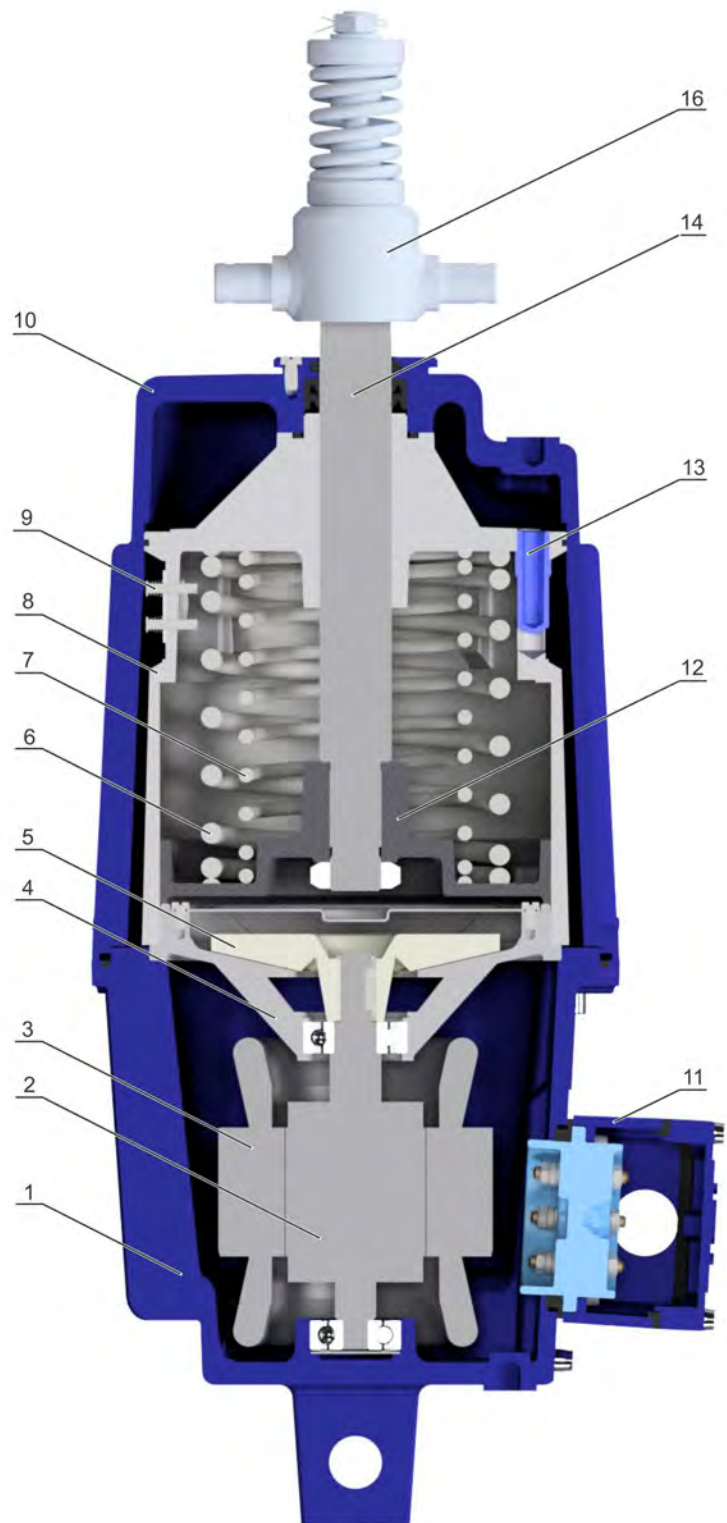



Pushing force gradually increase during 0.1 – 0.15 s, which provide very soft start of the rod. Electric motor has excellent cooling since transformer oil transfers heat to device housing and over the fins is transferred to the environment.

This device construction provides a constant output force, regardless of the position of the piston rod and the possibility of continuous operation without overloading. Switching off the electric motor, outside load caused the backward movement. Oil under the piston is suppressed back through the circuit of the turbine and through the corresponding holes exceeds into the zone above the piston. Oil level in device should be on the down blade of the filling port on upper housing (10) (device is in the vertical position). In the case of recharge, previously removed regulating screw (13).

Any position of the rod could be chosen for the output position. This is very important for brake releasing application, because thus compensate for brake linings wear. It is recommended that the brake should be adjusted (when it is completely closed) for 1/3 stroke of the rod.

Constructive, all sizes based on the same principle, except ESM-320, which, due required pushing force, have twostage turbine circuit. Thus was obtained the required pushing force from the device which has the same external dimensions like ESM-250.

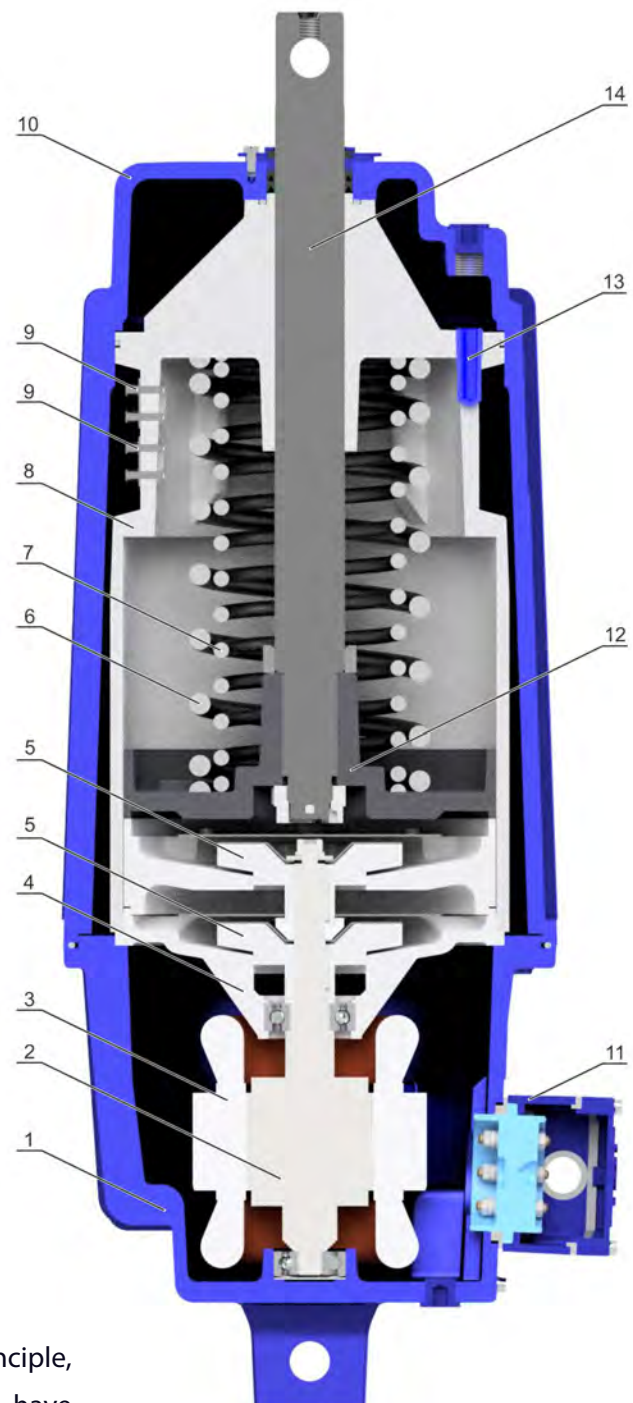

*According to the customer request, several versions also available:*

**Device with return springs C (6,7)**

One or two springs are mounted upper the piston. The piston forced back to the start position by the spring, after the motor switching off. There are three versions of the device, depends of the spring force: internal, external and both of them. It should be considered that the spring force reduces the nominal output force. The nominal return spring force is given according to the piston position on the 1/3 stroke. In full extract position of the rod, real return force exceeds nominal value for approximately 20%, in full retract position, pushing force is reduced for 10%.

**Device with shock absorber R (16)**

The shock absorber, fixed on the rod, prevents starting and stopping shocks and enables swiveling of the brake mechanism around the rod axe and around the perpendicular axe. This provides gradual increasing of the braking force up to a maximum.

**Device with speed control valve (9)**

The speed control valve is build on the cylinder holes and, depends of the type, prevent the one of the flow directions. There are few types of speed controls valves:

**Check valve for the lifting speed control - H.**

In case of the piston movement to the upper position, check valve is closed so the flow is enabling only through the port beside the adjustment screw (13). Then the speed is determined by the screw position. When the piston moves down, the check valve is opened and speed is maximal. Turning the adjustment screw in clockwise direction produces lower, counter clockwise higher speed. Before the adjusting it is necessary to remove the socket screw for filling.



### Check valve for the lowering speed control - S.

The function of the valve is opposite as already described, the downward speed is determined by the screw position.

### Throttle valve for the speed control in the both directions - D.

The flow is restricted in the both of the directions and it always depends of the adjustment screw position.

*It should be considered that these valves reduce speed of the device. If the maximum speed is necessary, the valves should not be used!*

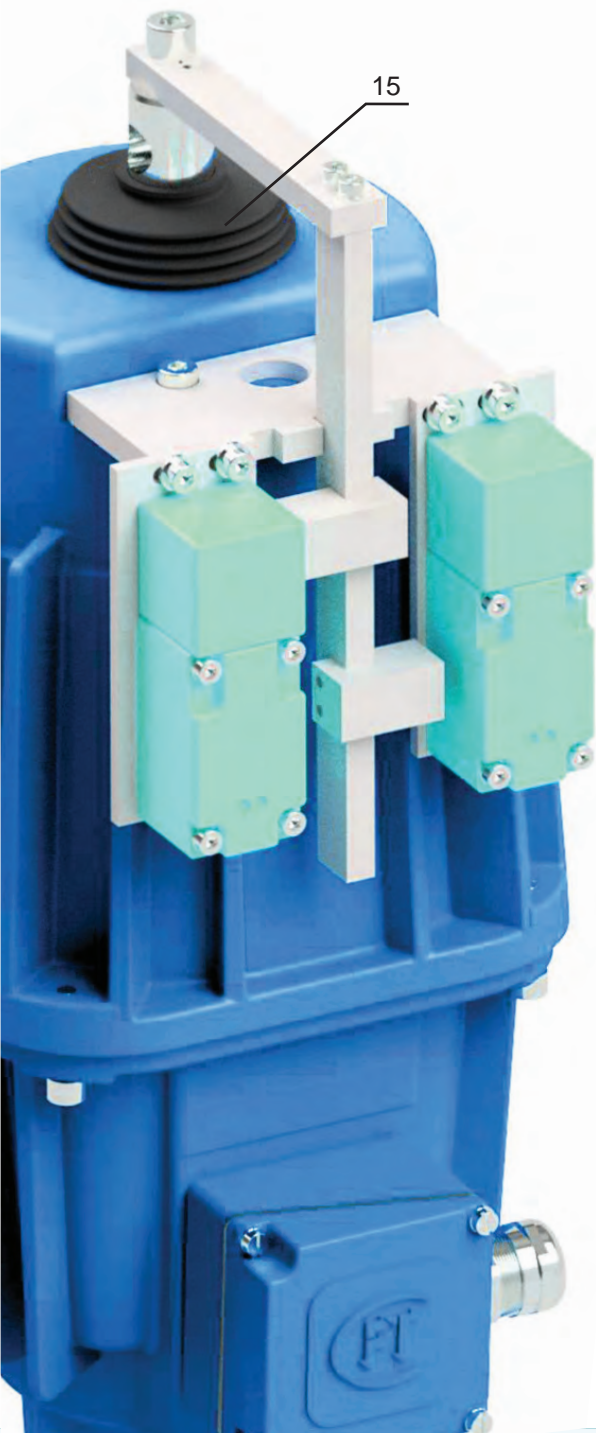

### Device with cover protection (15)

The cover protects the rod and seal set from dust penetration. It allows long life of the device in heavy operating conditions (surface minings and cement industry).

### Working signalisation of the device

- Device with external mechanical switch **Im** and **Im1** (brake open, linings worn)
- Device with inside mechanical switch **MP** (brake open)
- Device with external inductive switch **In** and **In1** (brake open, linings worn)
- Device with inside magnet-inductive switch **Lk2** and **Lk4** (brake open, linings worn)

We meet the special customer requests for voltage and frequency. For extremely hard operation conditions, such as permanent operation under tropic temperature, or for the periodical operation under extremely low temperature, we used special seals, electric motors and adequate synthetically oils. To choice the best solution, we recommend to contact our experts.



## VARIANTS OF INSTALLATION

The device is possible to use in vertical, horizontal (lifting rod in horizontal position  $\pm 30^\circ$ ) or inverted position. In the vertical position, installation and operation are easiest. In the horizontal and inverted positions, the device may be installed so that the terminal box will be located at the side, provided the symbol „ II “ was added after the type designation in the order. If in the horizontal service position space considerations require to mount the terminal box either on top or on the bottom, a modification of the device is required and has to be carried out by a specialist. When ordering this version, the symbol „ I “ must be added after the type designation. If the devices are to be used in an inverted position (lifting rod vertically downwards  $\pm 60^\circ$ ), consultation with manufacturer is necessary.



**VARIANT "II"**

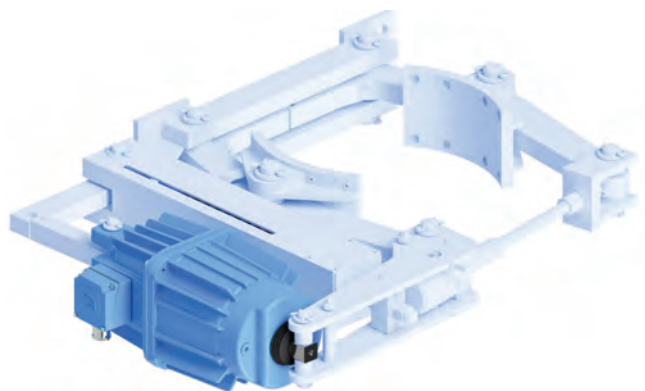
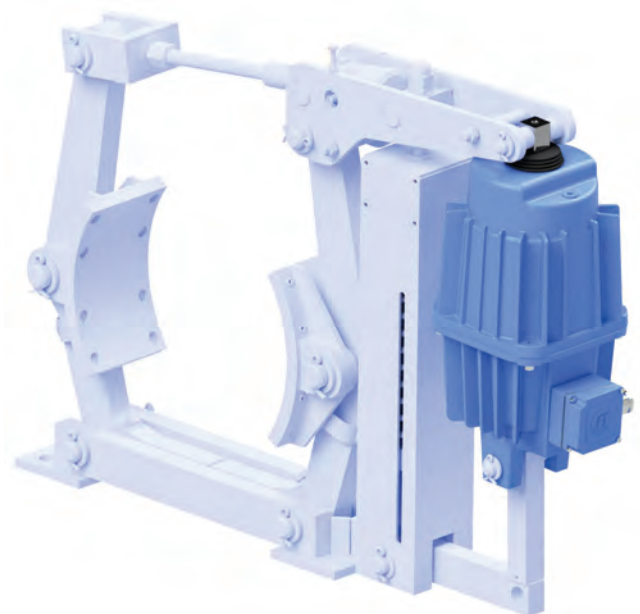

**EXAMPLES FOR VARIANT "II"**





**EXAMPLE FOR VARIANT "I"**

The point is that, when installing the device in a horizontal position, the plane in which the piston rod **(14)** and the control bolt **(13)** are located are horizontal. In this way, the device will work properly and have adequate technical characteristics.



**VARIANT "I"**

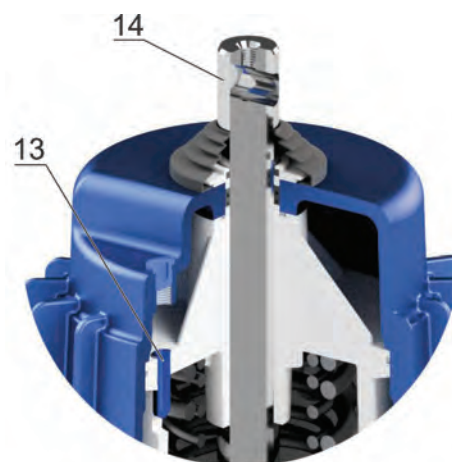

**External mechanical switch  
“Im” and “Im1”**



**External inductive switch  
“In” and “In1”**



Microswitch is build on the outside of cylinder. It is activate when the piston is in the top position. In a magnetic inductive switch, switches are also built on the outside of the cylinder and activates them a permanent magnet built in the piston. The advantage of this solution is that the switches are fully protected from external influences and in this way are very reliable in the work. Linkage is done in connecting box.

**Internal mechanical switch  
"MP"**

**Internal magnet-inductive switch  
"Lk2" and "Lk4"**

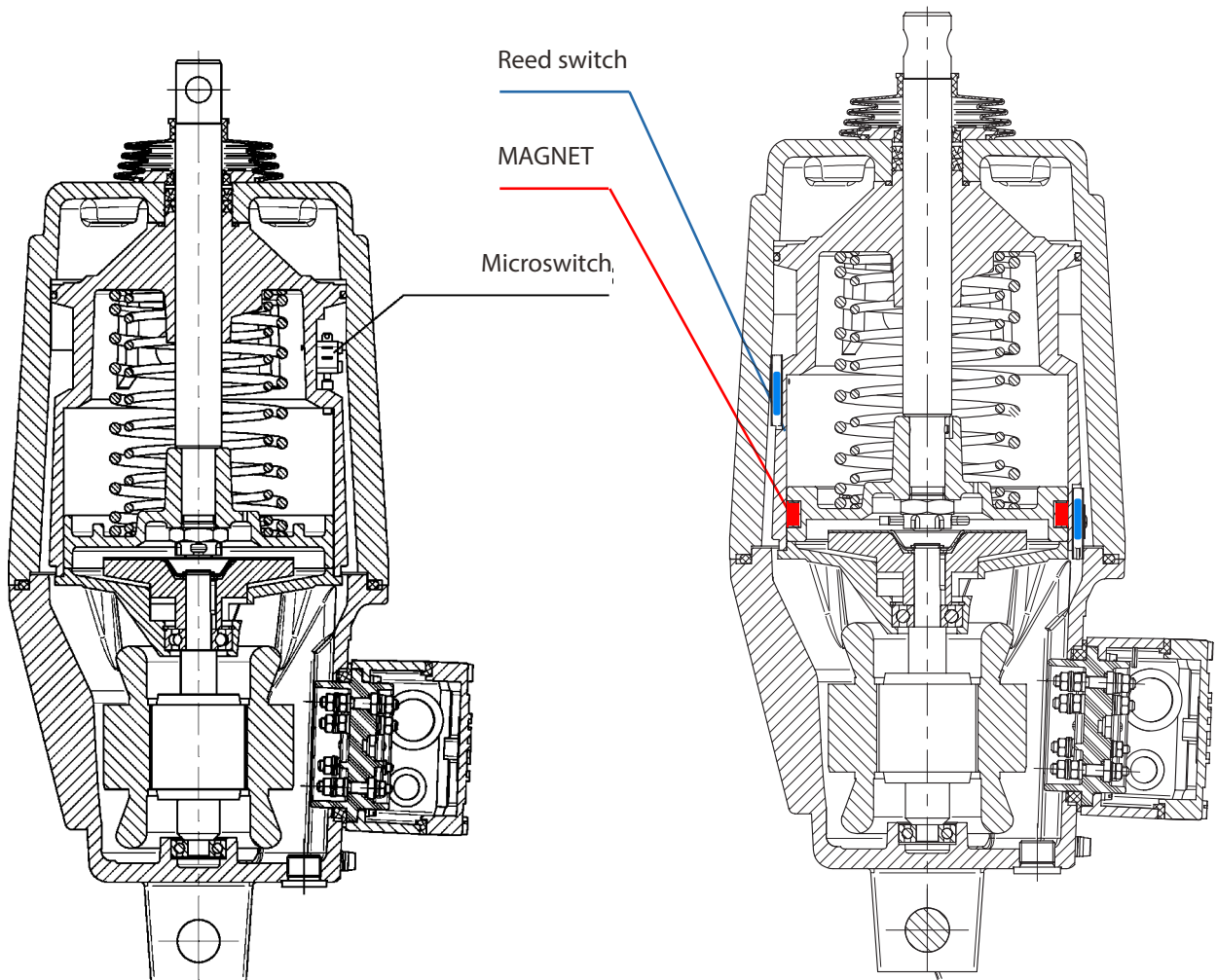

**Connecting box for device  
variant "MP" and "Lk2"**

**Connecting box for  
device variant "Lk4"**

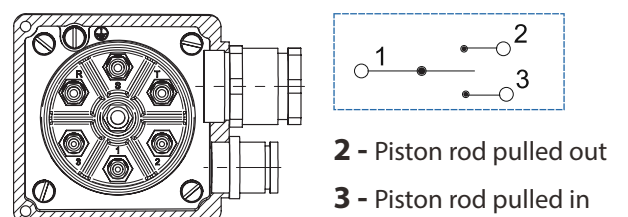
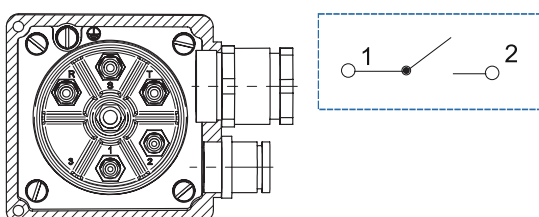

# ELECTROHYDRAULIC THRUSTERS **F-EHT** 12.5-50 to 250-60

TECHNICAL CHARACTERISTICS OF DEVICES

Size	Type	Nom. stroke	Nominal pushing force	Nominal return force	Power	Mass	Lifting time	Lowering time
		mm	N	N	W	kg	s	s
1	F-EHT 12.5-50 F-EHT 12.5-50V F-EHT 12.5-50F F-EHT 12.5-50FV	50	200	0 0 130 130	150	11.3	0.55	0.65
1	F-EHT 20-50 F-EHT 20-50V F-EHT 20-50F F-EHT 20-50FV	50	200	0 0 200 200	150	11.3	0.55	0.65
2	F-EHT 32-50 F-EHT 32-50V F-EHT 32-50F F-EHT 32-50FV	50	500	0 0 330 330	200	15.1	0.55	0.65
2	F-EHT 50-50 F-EHT 50-50V F-EHT 50-50F F-EHT 50-50FV	50	500	0 0 485 485	200	15.1	0.55	0.65
3	F-EHT 80-60 F-EHT 80-60V F-EHT 80-60F F-EHT 80-60FV	60	1250	0 0 775 775	350	24	0.55	0.6
3.1	F-EHT 125-60 F-EHT 125-60V F-EHT 125-60F F-EHT 125-60FV	60	1250	0 0 1290 1290	400	24	0.65	0.6
3.2	F-EHT 125-120 F-EHT 125-120V F-EHT 125-120F F-EHT 125-120FV	120	1250	0 0 820 820	400	28	0.65	0.6
4	F-EHT 200-60 F-EHT 200-60V F-EHT 200-60F F-EHT 200-60FV	60	2500	0 0 1910 1910	500	40.5	0.7	0.6
4	F-EHT 250-60 F-EHT 250-60V F-EHT 250-60F F-EHT 250-60FV	60	2850	0 0 2500 2500	500	40.5	0.7	0.6
4.1	F-EHT 200-120 F-EHT 200-120V F-EHT 200-120F F-EHT 200-120FV	120	2500	0 0 1360 1360	500	48	0.7	0.65

V with valve for lowering speed control

F with return springs



		Standard variant	For high temperatures		For low temperatures	
Symbol		-	T	TW06	TW07	L
Environment temperature	maximum	+40°C	+45°C	+60°C	+70°C	+40°C
	minimum	-25°C	-25°C	-10°C	-10°C	-45°C
Hydraulic fluid - oil type		Insulation oil NYNAS NYTRO 4000X			AEROSHELL FLUID 41	
Voltage and motor frequency		3 x 400V 50Hz				
Duty of device		2.000 cycles/h or ED 100% (S1)	350 cycles/h or ED 35% (S3)	250 cycles/h or ED 25% (S3)	2.000 cycles/h or ED 100% (S1)	
Mechanical protection		IP 66				
Variant on customer request	Voltage of electromotor		od 200V do 660V			
	Frequency		od 42Hz do 60Hz			
	Work control	Mechanical switch	Im	External mechanical control sensor signals that the brake is raised (open)		Voltage 24...250V AC/DC; current 2,5A; external IP65: The guaranteed activation point is max. 0,3mm from the maximum position of the activated thruster
			Im1	External mechanical control sensor signals that the brake is raised (open) and brake lining are worn		
			MP	Internal mechanical control sensor signals that the brake is raised (open)		
	Inductive switch	In	External inductive control sensor signals that the brake is raised (open)		Voltage 15...250V AC 500 mA 45...65 Hz NO/NC	
		In1	External inductive control sensor signals that the brake is raised (open) and brake lining are worn			
	Magnetic-inductive switch	Lk2	Internal control sensor signals that the brake is raised (open)		Voltage 24...250V AC/DC; current 0,5A; The guaranteed activation point is max. 5mm from the maximum position of the activated thruster	
Lk4		Internal control sensor signals that the brake is raised (open) and brake lining are worn				

### NOTES:

- Nominal pushing force for the device without a spring, is a declared force on the piston rod in the output direction. Maximum pushing force is ~ 50% higher. In devices with spring it is reduced by force springs.
- Nominal return force is a force of the spring for returning the piston rod and this information related to the 1/3 piston rod stroke. Tolerance is ±10%.
- The weight of the device and oil are approximate (depending on additional equipment).
- Time of lifting and lowering is related to a variant of the device without irreversible valve with built-in springs, i.e. with the corresponding external load. Tolerance is ±10%. In devices with built-in non return valve min. lifting and lowering time is greater for ~ 25%, while by the wring screw (13) can be continuously adjusted up to a maximum of 3- 5s for a stroke rate 50-60mm, 8-12s for the stroke rate 100 mm and 10-15s for the stroke rate 160mm.
- Nominal power and current refer to temperature of the device 20°C. Lowering temperature causes an increase in oil viscosity, in which case the nominal value of the power and current are growing and can be up to 50% higher.

### POSITION OF TERMINAL BOX WHEN THE DEVICE WORKS IN A HORIZONTAL POSITION

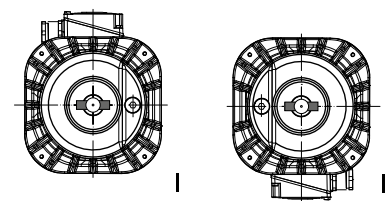

Foot bolt horizontal

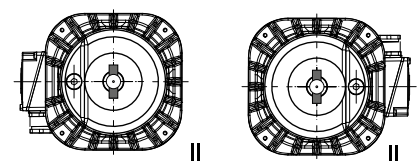

Foot bolt vertical

## INSTALLATION DRAWING

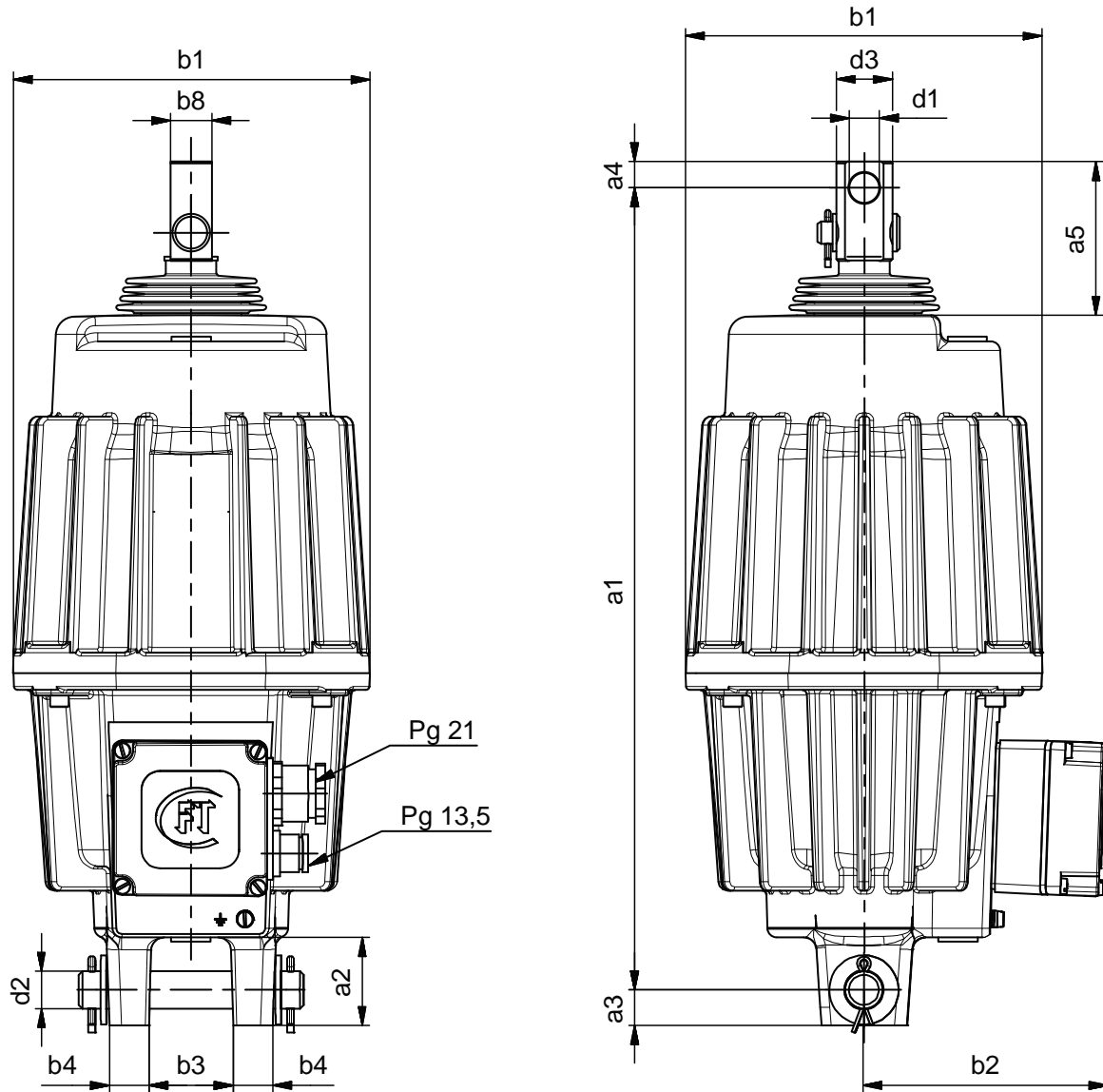

### INSTALLATION DIMENSIONS:

DIMENSIONS	$a_1^{+1}$	$a_2^{+1}$	$a_3^{+1}$	$a_4^{+0.2}$	$a_5$	$b_1^{+1}$	$b_2^{+1}$	$b_3^{+1}$	$b_4^{+1}$	$b_8^{-0.2}$	$d_1^{F9}$	$d_2^{H11}$	$d_3^{+0.2}$
SIZE													
1	400	50	20	15	75	152	125	40	15	22	16	20	30
2	420	50	20	15	75	182	130	40	15	22	16	20	30
3	557	55	25	19	153	210	140	40	20	25	20	25	35
3.1	582	55	25	19	178	210	140	40	20	25	20	25	35
3.2	702	55	25	19	194	210	140	40	20	25	20	25	35
4	582	55	25	19	92	255	150	40	20	25	20	25	35
4.1	702	55	25	19	104	255	150	40	20	25	20	25	35

## ORDER INSTRUCTION

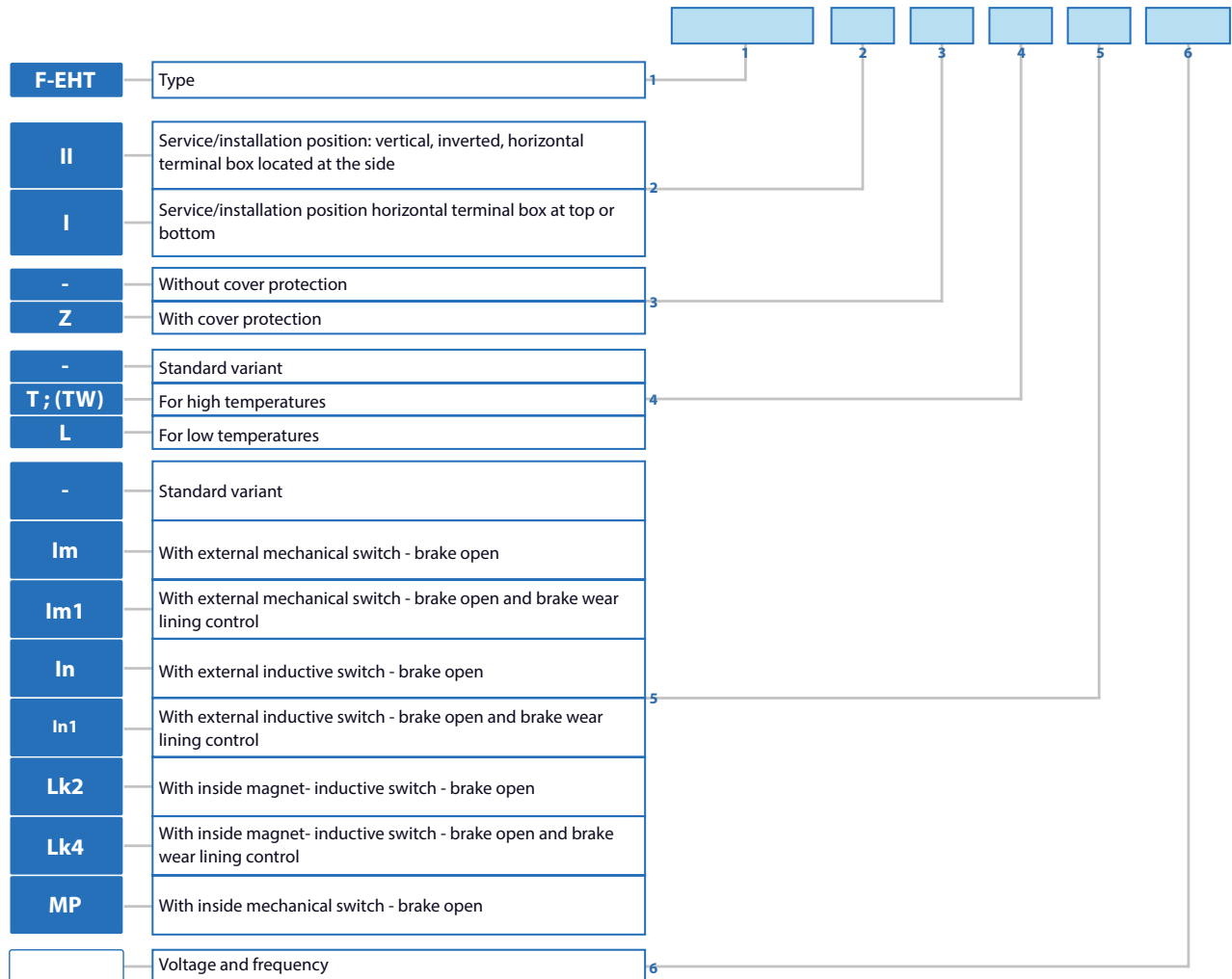

# ELECTROHYDRAULIC THRUSTERS F-EHT 338 to 2960



TECHNICAL CHARACTERISTICS OF DEVICES

Size	Type	Nom. stroke	Nominal pushing force	Nominal return force	Power	Mass	Lifting time	Lowering time
		mm	N	N	W	kg	s	s
3	F-EHT 338	75	450	0	350	24	0.6	0.7
3-F	F-EHT 338 F	50	450	420	350	24	0.6	0.7
3	F-EHT 375	50	750	0	350	24	0.5	0.55
3-F	F-EHT 375 F	50	750	700	350	24	0.5	0.55
3.1	F-EHT 900	120	750	0	350	24	1	0.7
4	F-EHT 1110	60	1850	0	500	40.5	0.8	0.6
4-F	F-EHT 1110-F	60	1850	1750	500	40.5	0.8	0.6
5	F-EHT 2960	160	1850	0	500	49	1.8	1.1

F with return springs



		Standard variant	For high temperatures		For low temperatures	
Symbol		-	T	TW06	TW07	L
Environment temperature	maximum	+40°C	+45°C	+60°C	+70°C	+40°C
	minimum	-25°C	-25°C	-10°C	-10°C	-45°C
Hydraulic fluid - oil type		Insulation oil NYNAS NYTRO 4000X			AEROSHELL FLUID 41	
Voltage and motor frequency		3 x 400V 50Hz				
Duty of device		2.000 cycles/h or ED 100% (S1)	350 cycles/h or ED 35% (S3)	250 cycles/h or ED 25% (S3)	2.000 cycles/h or ED 100% (S1)	
Mechanical protection		IP 66				
Variant on customer request	Voltage of electromotor		od 200V do 660V			
	Frequency		od 42Hz do 60Hz			
	Work control	Mechanical switch	Im	External mechanical control sensor signals that the brake is raised (open)		Voltage 24...250V AC/DC; current 2,5A; external IP65: The guaranteed activation point is max. 0,3mm from the maximum position of the activated thruster
			Im1	External mechanical control sensor signals that the brake is raised (open) and brake lining are worn		
			MP	Internal mechanical control sensor signals that the brake is raised (open)		
	Inductive switch	In	External inductive control sensor signals that the brake is raised (open)		Voltage 15...250V AC 500 mA 45...65 Hz NO/NC	
		In1	External inductive control sensor signals that the brake is raised (open) and brake lining are worn			
	Magnetic-inductive switch	Lk2	Internal control sensor signals that the brake is raised (open)		Voltage 24...250V AC/DC; current 0,5A; The guaranteed activation point is max. 5mm from the maximum position of the activated thruster	
Lk4		Internal control sensor signals that the brake is raised (open) and brake lining are worn				

**NOTES:**

- Nominal pushing force for the device without a spring, is a declared force on the piston rod in the output direction. Maximum pushing force is ~ 50% higher. In devices with spring it is reduced by force springs.
- Nominal return force is a force of the spring for returning the piston rod and this information related to the 1/3 piston rod stroke. Tolerance is ±10%.
- The weight of the device and oil are approximate (depending on additional equipment).
- Time of lifting and lowering is related to a variant of the device without irreversible valve with built-in springs, i.e. with the corresponding external load. Tolerance is ±10%. In devices with built-in non return valve min. lifting and lowering time is greater for ~ 25%, while by the wring screw (13) can be continuously adjusted up to a maximum of 3- 5s for a stroke rate 50-60mm, 8-12s for the stroke rate 100 mm and 10-15s for the stroke rate 160mm.
- Nominal power and current refer to temperature of the device 20°C. Lowering temperature causes an increase in oil viscosity, in which case the nominal value of the power and current are growing and can be up to 50% higher.

**POSITION OF TERMINAL BOX WHEN THE DEVICE WORKS IN A HORIZONTAL POSITION**

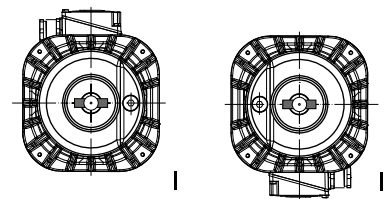

Foot bolt horizontal

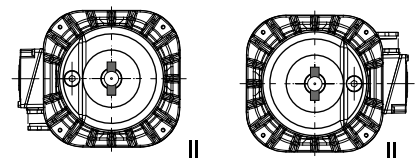

Foot bolt vertical

## INSTALLATION DRAWING

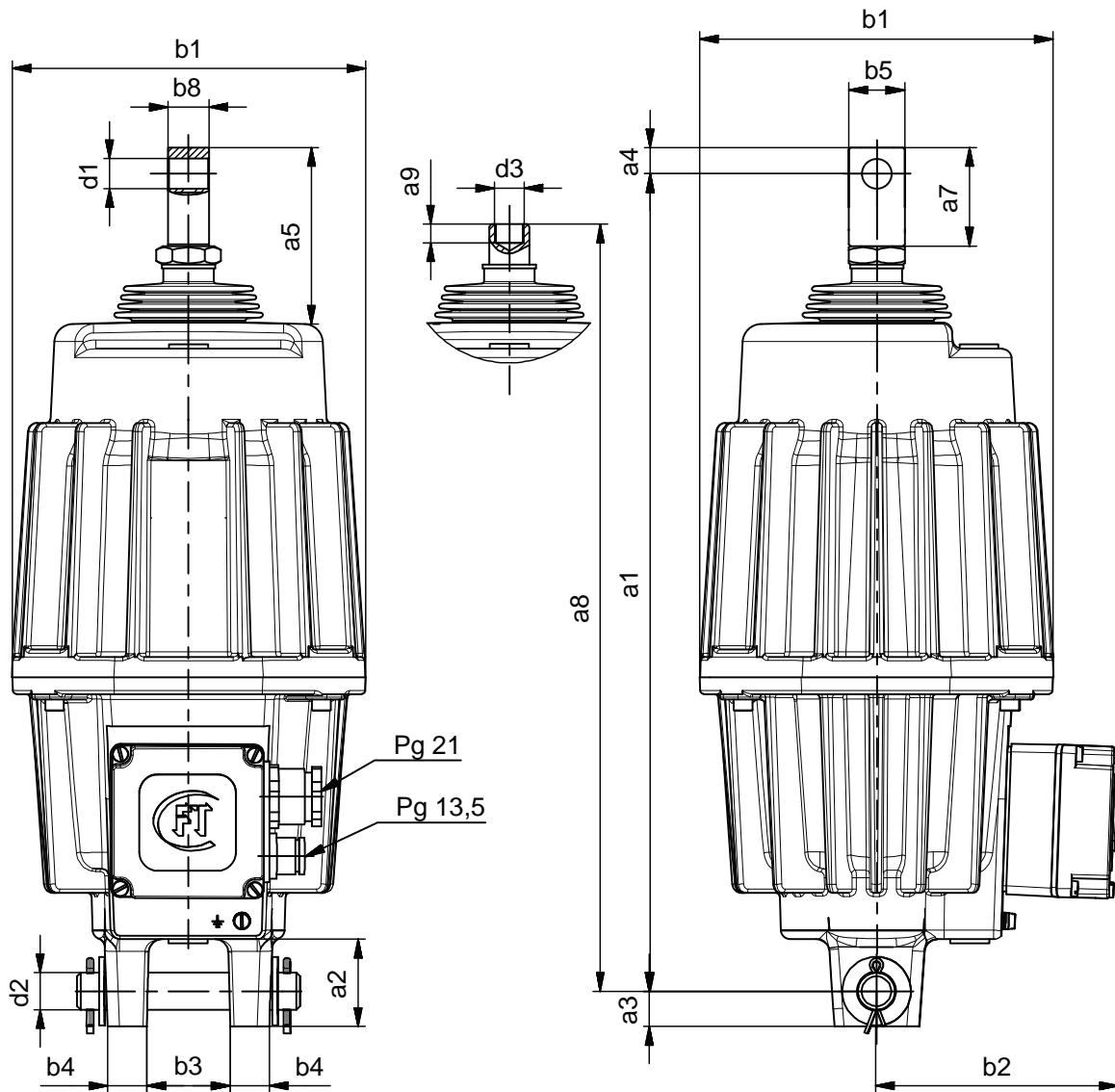

### INSTALLATION DIMENSIONS:

DIMENSIONS SIZE	a1	a2 <sup>+1</sup>	a3 <sup>+1</sup>	a4 <sup>+0.2</sup>	a5	a7 <sup>+0.2</sup>	a8 <sup>+1</sup>	a9 <sup>+0.2</sup>	b1 <sup>+1</sup>	b2 <sup>+1</sup>	b3 <sup>+1</sup>	b4 <sup>+1</sup>	b5 <sup>+0.2</sup>	b8 <sup>-0.2</sup>	d1 <sup>F9</sup>	d2 <sup>h11</sup>	d3
3	509	50	22	14	100	30			210	140	60	30	34	22	16	24	
3.1	609	50	22	15	96	57			210	140	60	30	34	25	16	24	
4	600	60	24	23	113	70			250	150	80	32	40	40	25	27	
5	700	60	24	23	105	70			255	150	80	32	40	40	25	27	
3-F		50	22				480	30	210	140	60	25				24	M16x1,5
4-F		60	24				568	30	255	150	80	32				27	M16x1,5

## ORDER INSTRUCTION

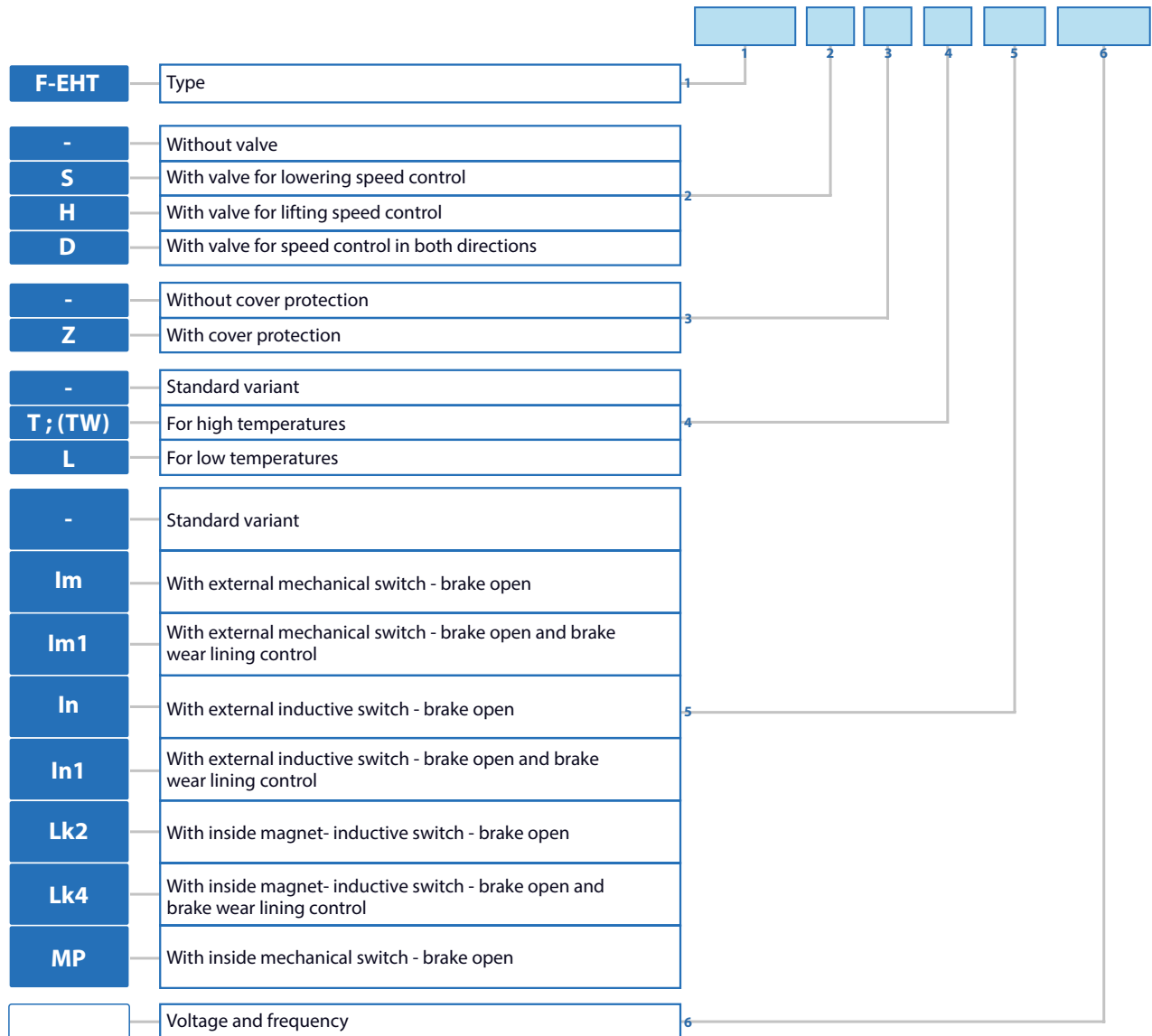



SERBIA  
36210 VRNJACKA BANJA  
Rudjinci 175/A  
tel/fax: +381-36-631-710  
E-mail: office@fluidotehnic.com  
Web: www.fluidotehnic.com

Matični broj: 06568939  
Šifra delatnosti: 2822  
PIB: 100918689  
Reg. broj: 11506568939  
Br. Reg. Upisa: 1-14429-00



## EC DECLARATION OF CONFORMITY / DECLARATION ON INSTALLATION

DEKLARACIJA O USAGLAŠENOSTI / DEKLARACIJA O UGRADNJI

**We hereby declare that the following product**

Izjavljujemo da su sledeći uređaji

**ELECTROHYDRAULIC THRUSTER**

ELEKTROHIDRAULIČNI PODIZAČI

**ESM 12/50...ESM320/100 ; ESM 120-40...ESM 3200-100**

**F-EB 12/50...F-EB 320/100 ; F-EB 120-40...F-EB 3200-100**

**F-BL-12 ... F-BL-320**

**F-EHT-12.5-50 ... F-EHT-250-60 ; F-EHT-338 ... F-EHT-2960**

**F-SZH 45/50 ... F-SZH 185/120**

**F-TGM 25 ... F-TGM 50**

**F-R 12/5 ... F-REH 320/120 N5H**

**F-Ed 12/4.1 ... F-Ed 301/12.1**

**Are designed and produced in accordance with the safety requirements according to the following regulations:**

Projektovani i proizvedeni u skladu sa bezbednosnim zahtevima prema sledećim propisima:

**Machinery Directive EC/2006/42**

(Mašinska direktiva EC/2006/42)

**Low voltage directive EC/2014/35**

(Niskonaponska direktiva EC/2014/35)

**in accordance with the following standards:**

i u skladu sa sledećim standardima:

**Safety of machinery - General principles for design**

- **Risk assessment and risk reduction EN ISO 12100:2010**

Bezbednost mašina - Opšti principi za projektovanje

- Ocena rizika i smanjenje rizika SRPS ISO 12100:2014

**Safety of machinery - Electrical equipment of machines - Part 1: EN 60204-1:2016**

Bezbednost mašina - Električna oprema mašina - Deo 1: EN 60204-1:2016

**Declaration on installation in the sense of EC Machinery Directive (2006/42/EC) Annex II B**

Izjava o ugradnji u skladu sa EC Mašinskom direktivom (2006/42/EC) Anex II B

**Electrohydraulic thrusters of "FLUIDOTEHNIC" assemble into mechanical devices and equipment. Start-up is not admissible unless it has been verified that the whole equipment, meets the requirements defined in the EC machinery Directive (2006/42/EC)**

Elektrohidraulični podizači "FLUIDOTEHNIC"-a se ugrađuju u drugu opremu i dodatne uređaje. Pokretanje nije dozvoljeno sve dok i relevantna oprema u koju se ugrađuju ne bude u skladu sa Mašinskom direktivom (2006/42/EC)

**The manufacturer undertakes to supply the relevant information of incomplete machine on request to responsible inspector by electronic way. Technical documents of the machine is prepared in accordance with Annex VII, part B Machinery Directive (2006/42/EC)**

Proizvođač se obavezuje da će elektronskim putem dostaviti odgovarajuće podatke o delimično završenoj mašini nadležnom inspektor na njegov zahtev. Tehnička dokumentacija je izrađena u skladu sa Anexom 7, deo B Mašinske direktive.

Vrnjačka Banja, 01/02/2017 godine



Šljivić Miroslav, General Manager

The EC Declaration of Conformity is only valid in conjunction with confirmation that the device has been correctly applied, installed, inspected and maintained according to the operating instructions provided. The validity of the declaration will cease in case of any modification and/or supplement not previously approved by "FLUIDOTEHNIC".

Ova deklaracija o usaglašenosti važi samo u slučaju da je uređaj pravilno ugrađen, iskontrolisan i da se koristi i održava u skladu sa uputstvom za rukovanje i održavanje. Važenje izjave prestaje u slučaju bilo kakve modifikacije ili dodatka koji nisu prethodno odobreni od "FLUIDOTEHNIC"-a.







- FLUIDOTEHNIC's production program is based on its own development. Thanks to that, all the products are the result of the engineering staff work, as well as the quality and skilled workers in manufacturing and installation. Each serial product during the conquest passes through the phase of prototype development, functional tests and check in real operating conditions. Following step is removal of all possible defects and then, based on that, test series is produced. This is how we achieve high quality of manufactured devices. In case of the individual production, after the functional testing, we deliver the product to the customer.
- Since its foundation FLUIDOTEHNIC Ltd. has been continuously investing both in the expansion of commercial building and the purchase of modern equipment for the production, control and techno-economic support. It is located in the industrial zone of Vrnjacka Banja, on a lot size ~ 2ha. It consists several buildings, connected into a functional whole area of 4000 m2. The whole complex is adjusted to the environment- we are taking good care of health, work safety and environmental protection.





- Market research, device development, technical assistance and personnel training free of charge for all our customers is the main task of this service. Many years of experience in the development tasks of hydraulics, pneumatics and lubrication techniques, as well as the latest computer technology guarantee that our customers will get the optimum technical solution. During the development, every device passes precisely defined procedure, starting from making the design concept, followed by manufacturing and testing prototypes and going into production.
- It consists of several facilities and departments: foundry of non-ferrous metals, mechanical drive, locksmith department, installation and technical control. All operations from the casting to the final machining are performed with the universal and software machines. Control and assembly is 100%. When the assembly is finished, each device is being tested on the test stand and on the basis of the results it gets the appropriate certificates and guarantees. On each call of the user, service teams come in as soon as possible, with spare parts and the necessary tools, regardless of whether the equipment is in warranty or out of warranty period.





**Fluidotehnic d.o.o.**

**Serbia**

36210 Vrnjacka Banja

Rudjinci 175/A

**Tel:** +381-(0)36-631-710

+381-(0)36-631-711

**Fax:** +381-(0)36-631-712

**[www.fluidotehnic.com](http://www.fluidotehnic.com)**

[office@fluidotehnic.com](mailto:office@fluidotehnic.com)

© Fluidotehnic doo

02/2018